

DEVELOPER'S APPROVAL *John B. Bye* 7-8-91

LEGEND

- UP UTILITY POLE
- SAN SANITARY SEWER
- W.M. WATER MAIN
- F.H. FIRE HYDRANT
- Flow Arrow FLOW ARROW
- Ground Elevation GROUND ELEVATION
- UG.T. UNDERGROUND TELEPHONE
- G GAS LINE
- SD STORM DRAINAGE
- EXIST. LOT LINES

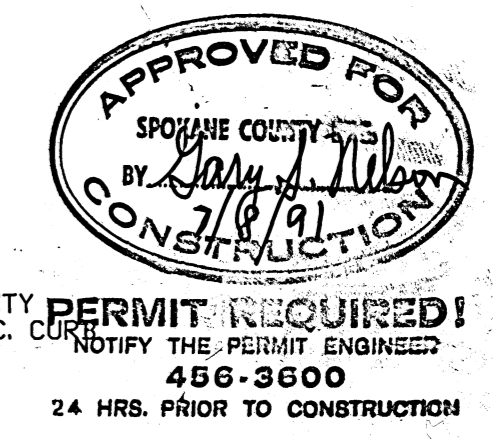
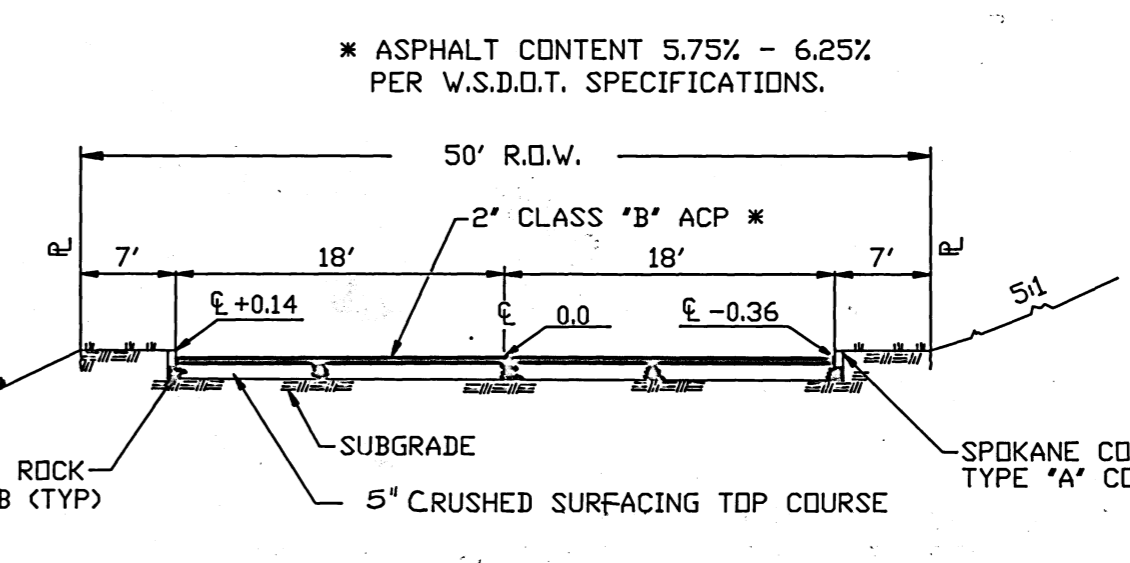

1 TYPICAL CROWNED STREET SECTION
NTS

NOTES:

- 1 CONSTRUCT SPOKANE COUNTY STANDARD STOP AND STREET NAME SIGN PER M.U.T.C.D. AT LOCATION SHOWN.
- 2 CONSTRUCT BARRICADE PER SPOKANE COUNTY STANDARDS AT END OF STUB. PROVIDE 3:1 SLOPE OFF THE END OF THIS STUB.
- 3 MAINTAIN GUTTER LINE SLOPE (0.008) THRU CUL-DE-SAC.
- 4 INSTALL WILBERT OUTFALL #4016 OR APPROVED EQUAL AT INLET AND OULET ENDS. BACKFILL BETWEEN BOX AND SLOPE.
- 5 2" OF A.C.P. TO BE PLACED OVER NATIVE SOIL ON HAVANA STREET BETWEEN 25th AVE. AND 26th AVE. PER THE DIRECTION OF THE CITY OF SPOKANE, PUBLIC WORKS DEPARTMENT.

REVISIONS				GRADE ORDINANCE LIST				CITY DATUM		SCALE	DATE	
BY	DATE	PROJ.	FROM	AS BUILT	TO	ACCEPT	FROM	TO	ORD. NO.	DATE	FILE NO.	DATE
GG	4/18/91						FROM	TO				
GG	3/25/91											
GG	2/28/91											

25TH AVENUE		TYPE OF IMPROVEMENT		STREET	
PROJECT NUMBER	PLAN NUMBER				